

Tools Required	
• Power drill	• Hammer
• Drill bits 30mm (1 3/16"), 25mm (1"), 20mm (3/4"), 16mm (5/8") & 10mm (3/8")	• Utility knife
• Phillips screwdriver	• Adhesive tape
• Chisel - 22mm (7/8")	• Pencil
• Chisel - 25mm (1")	• Awl
	• Tape measure

**BOX CONTENTS** – Check the contents of the box are correct according to the model.

**LEVER TO LEVER KIT PARTS ASSEMBLY**

1. Front plate and handle
2. Back plate and handle
3. Neoprene seals x 2
4. RED & BLUE tipped spindles
5. Fixing bolts x 4 (1 x spare)
6. Front plate cylinder cover
7. Allen keys x 2
8. Keyhole escutcheons
9. Latch, strike & 4 screws
10. Code change keys
11. Latch support post
12. Code change tool

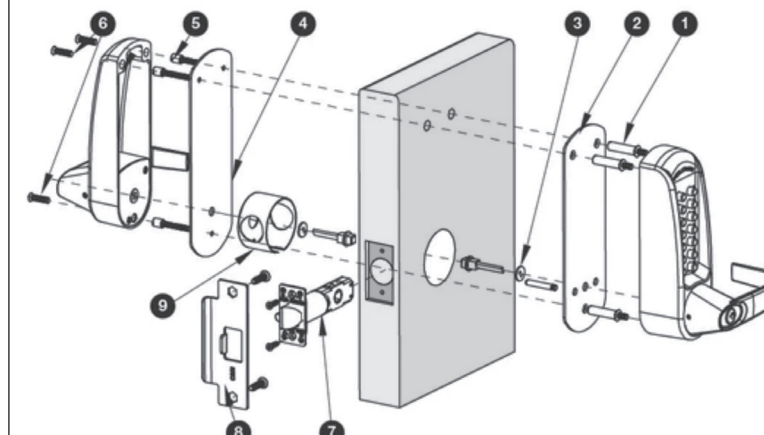
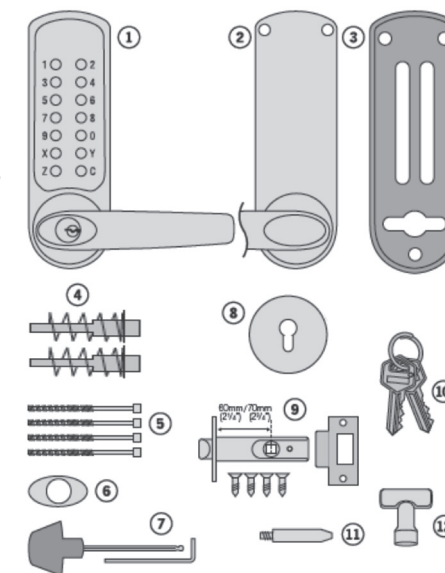

1. Fixing Posts x 3
2. Outer Cover Plate
3. Spindle Washers x 8
4. Inner Cover Plate
5. Fixing Bolts x 3
6. Short Fixing Bolts x 3
7. Fire Latch 70mm (2 3/4")
8. ASA Strike Plate
9. Fire Cup

## INSTALLATION OF CL610 LOCKS

The model CL610 has a tubular, deadlocking latch and may be used as a new installation on a door, or where an existing latch is to be replaced.

*Note: Align the template to suit the locks backset: 2-3/8" (60mm) standard or 2-3/4" (70mm).*

**STEP 1**  
Lightly mark a height line on the edge and both faces of the door, and on the door jamb, to indicate the top of the lock when fitted. Crease the template (standard) along the dotted line, and tape it to the door with the top in line with the height line. Mark the 3 x 3/8" (10mm) and the 1 x 1-3/16" (30mm) holes and drill.

*Note: When fitting to a door with existing door prep hole, only top two 3/8" (10mm) holes need to be marked.*

Mark the center of the door edge on the Center Line of Latch. Remove the template and apply it to the other side of the door, aligning it accurately with the first Center Line of Latch mark. Mark the 4 holes again.

*Note: Space required above latch body for cam to rotate.*

**STEP 2**  
Keeping the drill square to the door, drill a 1" (25mm) hole in center of door edge, deep enough to accept the latch.

**STEP 3**  
Keeping the drill level and square to the door, drill the 3/8"–1-3/16" (10mm and 30mm) holes from both sides of the door to increase accuracy and to avoid splintering out the door face.

## STEP 4

Put the latch into the hole and, holding it square to the door edge, draw around the faceplate. Remove the latch and score the outline with a Stanley knife to avoid splitting when chiseling. Chisel a rebate to allow the latch to fit flush to the surface.

## STEP 5

Fix the latch with the wood screws, with the bevel towards the door frame.

## STEP 6

Fitting the strike plate. *N.B. The plunger beside the latchbolt deadlocks it, to protect against manipulation or 'shimming'. The strike plate must be accurately installed so that the plunger CANNOT enter the aperture when the door is closed, even if it is slammed shut. Position the strike plate on the door frame so that it lines up with the flat of the latchbolt, and NOT the plunger. Mark the positions of the fixing screws, and draw around the aperture of the strike plate. Chisel out the aperture 3/8" (15mm) deep to receive the latchbolt. Fix the strike plate to the surface of the frame using only the top fixing screw. Gently close the door and check that the latchbolt enters the aperture easily, and is held without too much 'play'. When satisfied, draw around the outline of the strike plate, remove it and cut a rebate to enable the faceplate to lie flush with the surface. Re-fix the strike plate using both screws.*

## STEP 7

Take the BLUE or RED tipped spindle and fit to the code side according to the hand of your door (see diagram). Fit remaining spindle to inside - non code side.



## STEP 8

Fit the latch support post into back of the code side front plate according to the hand of your door, A for a right hand door, or B for a left hand door (see diagram).

## STEP 9

Cut three of the socket head bolts to the required length for your door. Approximate overall length should be door thickness plus 1" (25mm) to allow about 3/8" (10mm) of threaded bolt to enter the outside plate.

## STEP 10

Apply the front and back plates, with the neoprene seals in position, against the door, over the protruding ends of the spindle.

## STEP 11

Fix the two plates together using the socket head bolts, starting with the top fixing. Ensure that the two plates are truly vertical and then tighten the bolts using the 'T' shaped Allen key. Do not use excessive force.

## STEP 12

Check that the lever handles are correctly fitted for the hand of door. To change the hand of a lever handle, loosen the grub screw with the small Allen key, reverse the lever handle and fully tighten the grub screw.

## STEP 13

Before closing the door, enter the code and ensure that the latchbolt will retract when the lever handle is depressed. Now check the operation of the inside lever handle. If there is any binding of the handles or latch then loosen the bolts and reposition the plates slightly until the correct position is found, and then re-tighten the bolts.

HEIGHT LINE

MECHANICAL  
CODELOCK  
600

610/615 INSTALLATION TEMPLATE

FOLD ALONG DOOR EDGE

CENTRE LINE OF LATCH

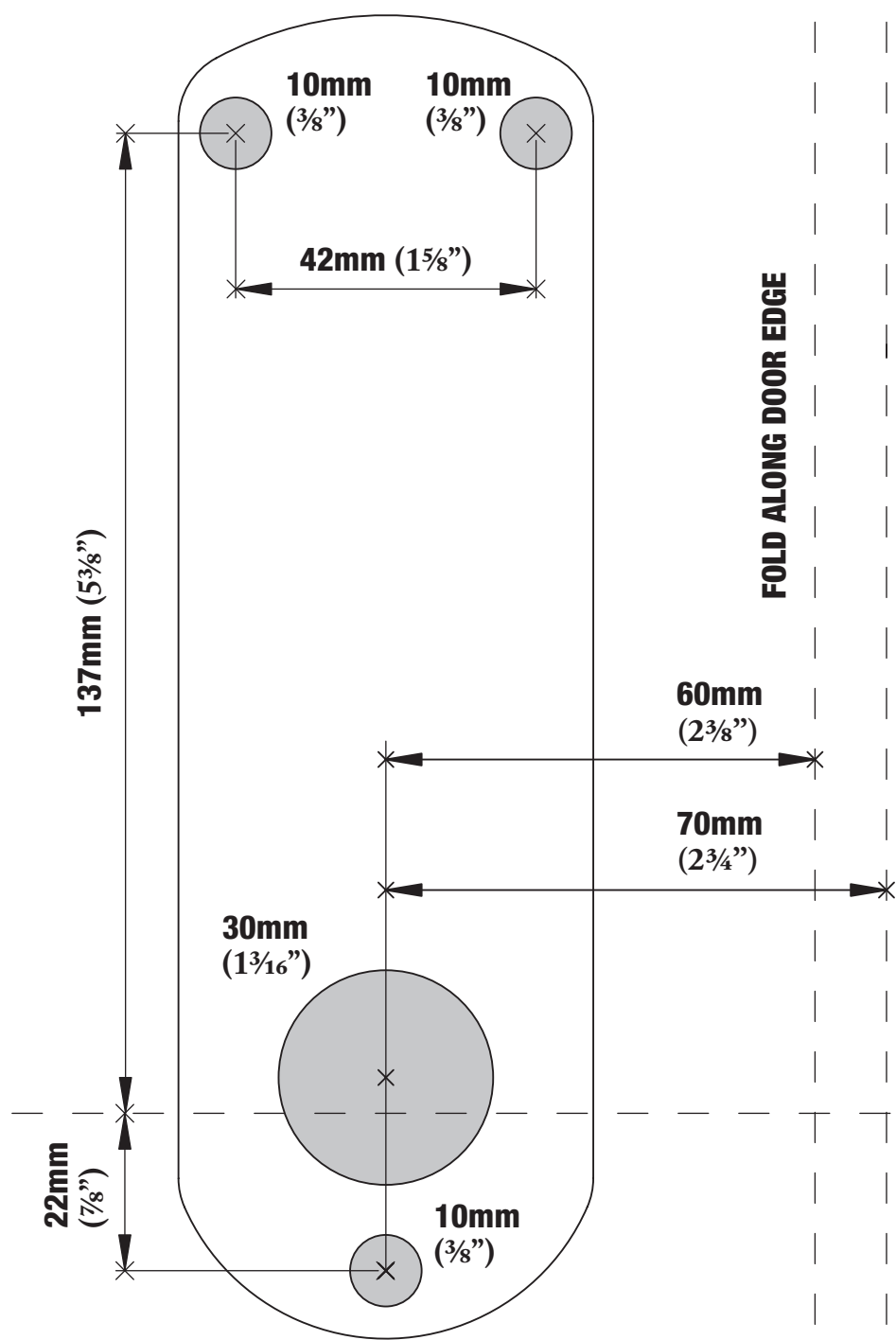

IT-600ML-V01

PAGE INTENTIONALLY LEFT BLANK

