

Tools Required	
• Phillips screwdriver	• Hammer
• Pliers (for cutting bolts)	• Utility knife
• Chisel - 25mm (1")	• Adhesive tape
• Power drill	• Pencil
• Drill bits 10mm (3/8"), 25mm (1"), and 54mm (2-1/8")	• Bradawl
	• Tape measure

**CODELOCK
5000
ELECTRONIC**

INSTALLATION TEMPLATE

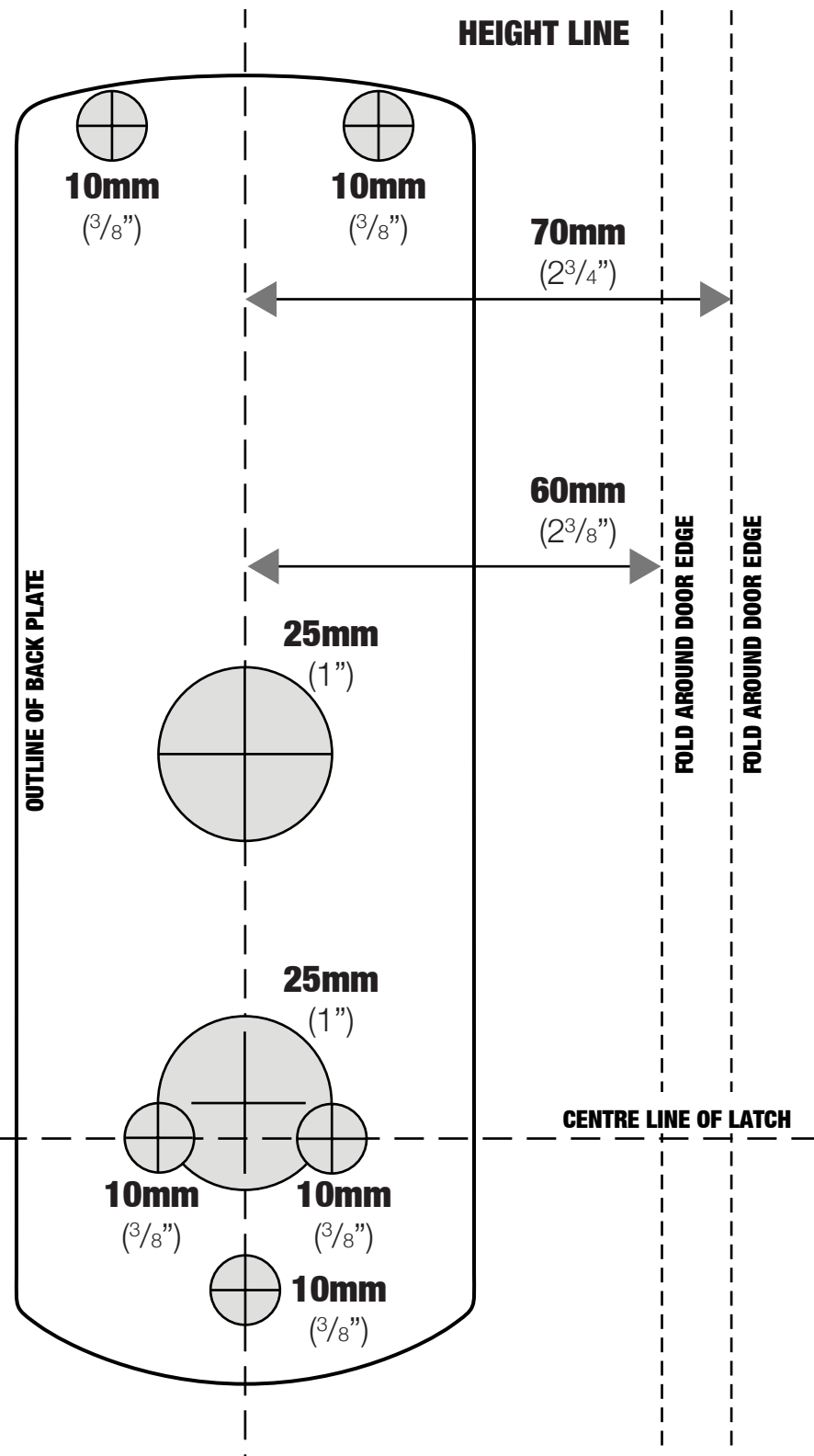

BOX CONTENTS – Check the contents of the box are correct

Item	CL5510	CL5510PK
1 Front Plate	✓	✓
2 Back Plate	✓	-
3 Lever Handles	✓	✓ x1
4 Gaskets	✓	✓
5 Sprung Spindle x 1	✓	✓
6 Fire Cup	✓	-
7 1.5v AA Batteries x 4	✓	✓
8 Mortice Latch, Strike and 4 Screws	✓	-
9 Fixing Bolts x 4 incl. spare	✓	✓
10 Cable Tube, Ring Nut and Cap	✓	-
11 Alignment Insert	✓	-
12 Latch Support Post	✓	-
13 Allen Keys	✓	✓
14 Cable Connections for REM 1 and REM 2	✓	✓
15 Front Plate Cylinder Keys	✓	✓
16 Front Plate Cylinder Cover	✓	✓
17 Classroom Function Tailpiece	✓	-
18 Battery Pack	-	✓

This box should also contain the installation template and getting started guide.

Illustration of CL5510 only

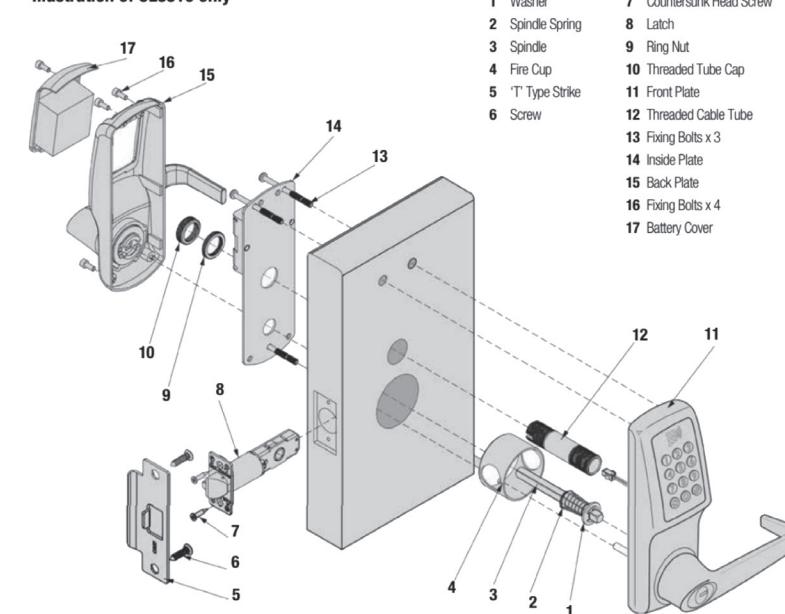

CL5510 LATCH FUNCTION

Outside handle turns freely without operating the latchbolt. When the code is entered the keypad will flash blue and the handle will retract the latchbolt. The latch automatically locks the door when closed. The key will open the door without the code.

OPERATIONS CHECK

- Familiarize yourself with the operation of the lock and check that all the parts work properly.
- Remove the battery cover from the back plate and install the 4 x AA cells supplied.
- Connect the cables from the front plate and back plate. A BEEP should be heard when you do this. If no BEEP is heard then check that the batteries are correctly installed.
- Place the long spindle in the front plate socket and using finger grip only, test that the spindle is easily moved 80° in both directions. Leave socket in the centered position.
- Enter the factory Master Code #12345678.
- The keypad will flash blue and the spindle should not turn as before. After 5 seconds the keypad will flash red and the spindle should turn easily again. This confirms that the clutch engaged correctly when the code was entered.

N.B. When the Master Code is entered 3 times consecutively without performing a programming function, a penalty time of 10 seconds is activated.

- Disconnect the cables.

SPECIAL FIXING NOTE

Remote Release Option

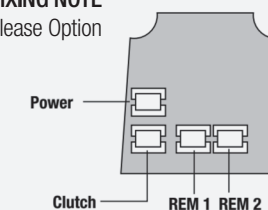

Cables are provided for the REM 1 and REM 2 terminals on the circuit board.

REM 1 is for connection to a reception desk push button or a door intercom system. Pressing the button will cause the keypad to flash blue on the lock and release the lock for the pre-set time.

REM 2 is for connection to the building alarm system to release a door in an emergency. This allows rooms, wards, offices to be easily checked to ensure that no person is trapped or overlooked during an emergency evacuation. When activated REM 2 will maintain the unlocked condition for 30 minutes, the keypad will flash red and BEEP during this time.

The lock will automatically lock again after 30 minutes. If necessary Program 7 can be used to re-lock before the end of the 30 minutes.

REM 1 and REM 2 do not require additional power. They are normally open contacts requiring a momentary or maintained signal to close.

INSTALLATION OF CL5510 LOCKS

Installation holes must be drilled in the correct positions. Lock components must be vertically and horizontally accurate in relation to each other and to the door.

WEDGE THE DOOR FIRMLY TO PREVENT MOVEMENT WHILE DRILLING AND CHISELING.

1. Lightly mark a height line on the edge and both faces of the door, to indicate the top of the lock when fitted. Crease the template along one of the dotted lines - 60mm (2 3/8") or 70mm (2 3/4") latch - and tape it to the door with the top in line with the height line. Mark the holes to be drilled. Mark the center line of latch on to the door edge. Apply the template to the other side of the door precisely against the height line and the center line of latch mark. Mark the holes to be drilled again. (See diagram A).

Diagram A

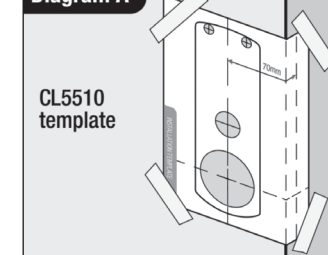

CL5510
template

2. Keeping the drill level and straight, drill a 25mm (1") hole in the center of the door edge to accept the latch. Put the latch into the hole and holding it square to the door edge, draw around the faceplate. Starting with the top and bottom cuts, chisel a rebate to allow the latch faceplate to fit flush with the door edge. Remove the latch.

3. Keeping the drill level and straight, drill the holes in the door face. Drill from both sides of the door to increase accuracy and to avoid damage to the other side when a drill goes right through.

4. Insert the fire cup into the 54mm (2 1/8") hole. N.B. open side of the fire cup to face code side with small bolt through hole at the bottom.

5. Re-insert the latch and fix the screws, with the bevel towards the door frame. (See diagram B).

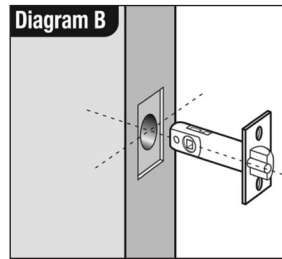

6. Fit the latch support post on the inside of the front plate, in outer hole side A for a left hand hung door and in outer hole B for a right hand hung door. (See diagram C).

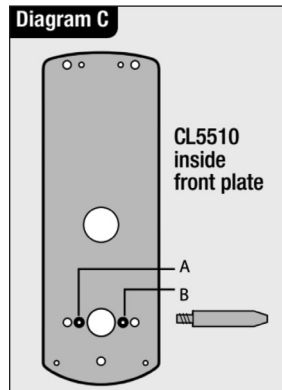

7. Screw the cable tube into the front plate, passing the cable through the tube. For doors less than 45mm (1 3/4") thick screw the tube all the way to the end of the thread. For doors more than 45mm (1 3/4") leave an appropriate amount of thread showing.
Example: For a 60mm (2 3/8") thick door leave 15mm (1/2") of thread showing.

8. Fit the self-adhesive gaskets to the front and back plates. The gaskets provide friction against the door so that it is not necessary to over-tighten the fixing bolts to provide stability.

9. Remove the five socket head bolts from the back plate (two are found under the battery cover). This will release the inside fixing plate.

10. Cut the fixing bolts to correct length. Measured from beneath the bolt head, the length should be the door thickness, plus approximately 15mm (1/2") to the nearest cutting point of the bolt.

N.B. Always cut the bolts at one of the cutting points so as not to damage a thread. Use the cutting edges of pliers to crimp strongly several times around the selected cutting point. The surplus end should break off quite easily.

11. Put the spindle into the latch with the spring on the front plate side of the door.

12. Apply the front plate over the spindle, passing the cable tube through the door and the latch support post through the latch. Place the fixing plate over the cable tube and spindle. Screw the ring nut onto the cable tube until finger tight. Fit the alignment insert over the spindle. Screw the fixing bolts through to the front plate. (See diagram D)

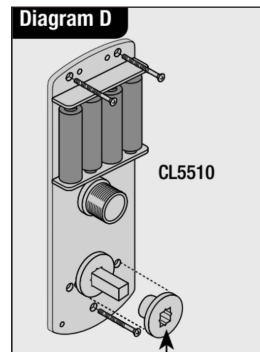

13. Check that the spindle turns freely, and the latch retracts and projects smoothly, with the alignment insert in place. If it is tight, loosen the fixing bolts slightly and adjust the position of the fixing plate until the spindle will turn freely. Tighten the fixing bolts. Test the spindle again. Do not over-tighten the bolts as this may cause the door to distort and affect the lock function. PLEASE REMOVE THE ALIGNMENT INSERT.

14. Connect the cables, storing any excess cable within the door. Screw end cap onto cable tube. Then install the batteries.

15. Fit the back plate over the fixing plate using the four socket head screws.

16. Fit the cylinder cover and outside handle to the front plate.

17. Fit the inside handle to the back plate.

18. The inside handle will now retract the latchbolt. The outside handle will turn freely without retracting the latch. Enter the factory Master Code #12345678. The keypad will flash blue and the outside handle will now retract the latch.

19. Fitting the strike plate. Position the strike plate on the door frame so that the aperture lines up with the flat of the latchbolt, and NOT the plunger. Mark the positions of the fixing screws and draw around the aperture of the strike plate. Chisel out the aperture to 15mm (1/2") deep to receive the latchbolt. Fix the strike plate to the surface of the frame using only the top fixing screw. Gently close the door and check that the latchbolt enters the aperture easily, and is held without too much 'play'. When satisfied, draw around the outline of the strike plate, remove it and cut a rebate to enable the strike plate to lie flush with the surface. Re-fix the strike plate using both screws.

N.B. The plunger beside the latchbolt deadlocks it to protect against manipulation or 'shimming'. The strike plate must be accurately installed so that the plunger CANNOT enter the aperture when the door is closed, even when it is slammed shut.

