



INSTRUCTIONS AND TEMPLATE FOR CL5000 SERIES PANIC KIT ELECTRONIC LOCK



CL5000 Electronic Lock Trim

Using the template on page 2, install the CL5000 Lock Trim with the Exit Device. Tape template to the door, mark the holes and drill where needed.

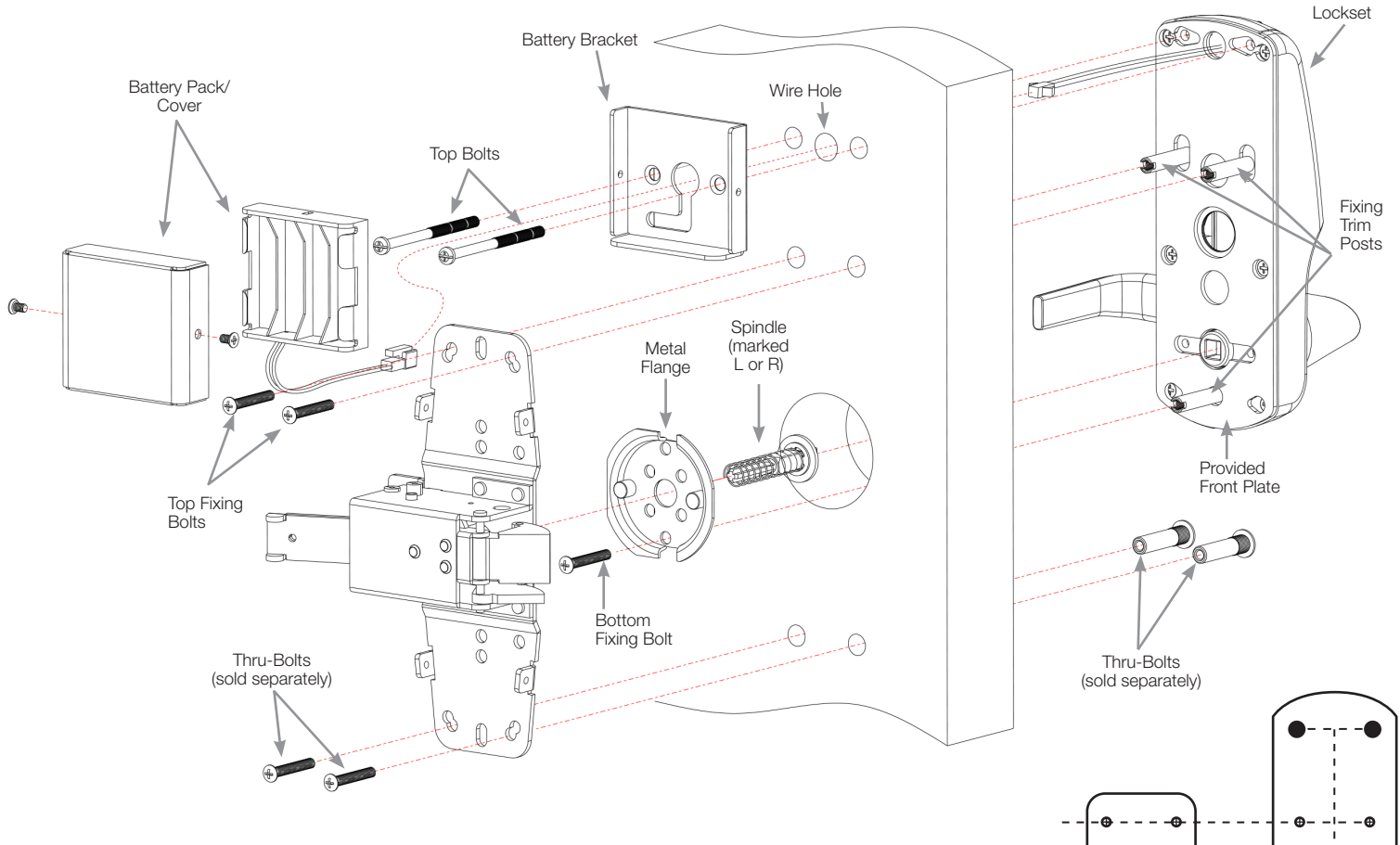

Installation Instruction

1. Tape template to the door and mark and drill holes where necessary.
2. Attach Fixing Trim Posts into the holes of front plate.
3. Attach lockset device to the door:
 - 1st: Screw two Top Bolts thru Battery Bracket, thru door and into Lockset,
 - 2nd: Attach Bottom Fixing Bolt into Fixing Post using Metal Flange when necessary.
4. Run battery wire terminal through the Wire Hole as indicated.
5. Attaching exit device to the door:
 - 1st: Screw Top Fixing Bolts into top Fixing Posts
 - 2nd: Attach bottom of exit with thru bolts (sold separately)
6. Fit the Spindle from the rear side spindle hole to the front plate.
7. Attach panic device to fixing posts, then at point insert fixing screws onto fixing post at point.
8. Plug in Battery Pack to the Lockset, place the wires into the door and attach Battery Pack to Bracket with Cover.

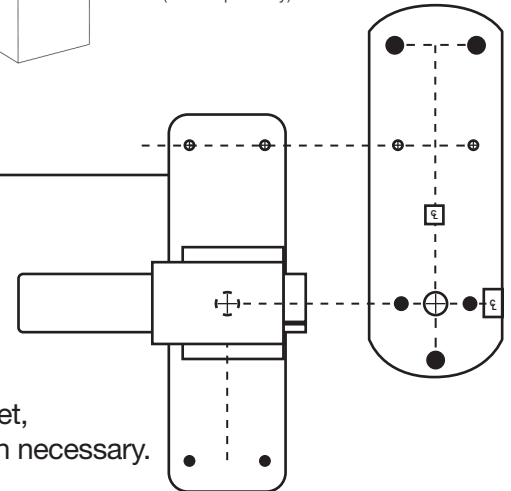

CL5000 Electronic Lock Trim

1. Align template center-line (CL) with the CL of the Exit Device (as illustrated). Tape template to the door, mark the holes and drill where needed.

Template
Actual Size

1" Square

Print PDF at 100%
Actual Size

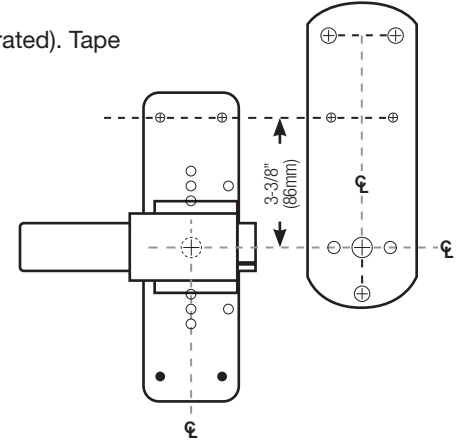
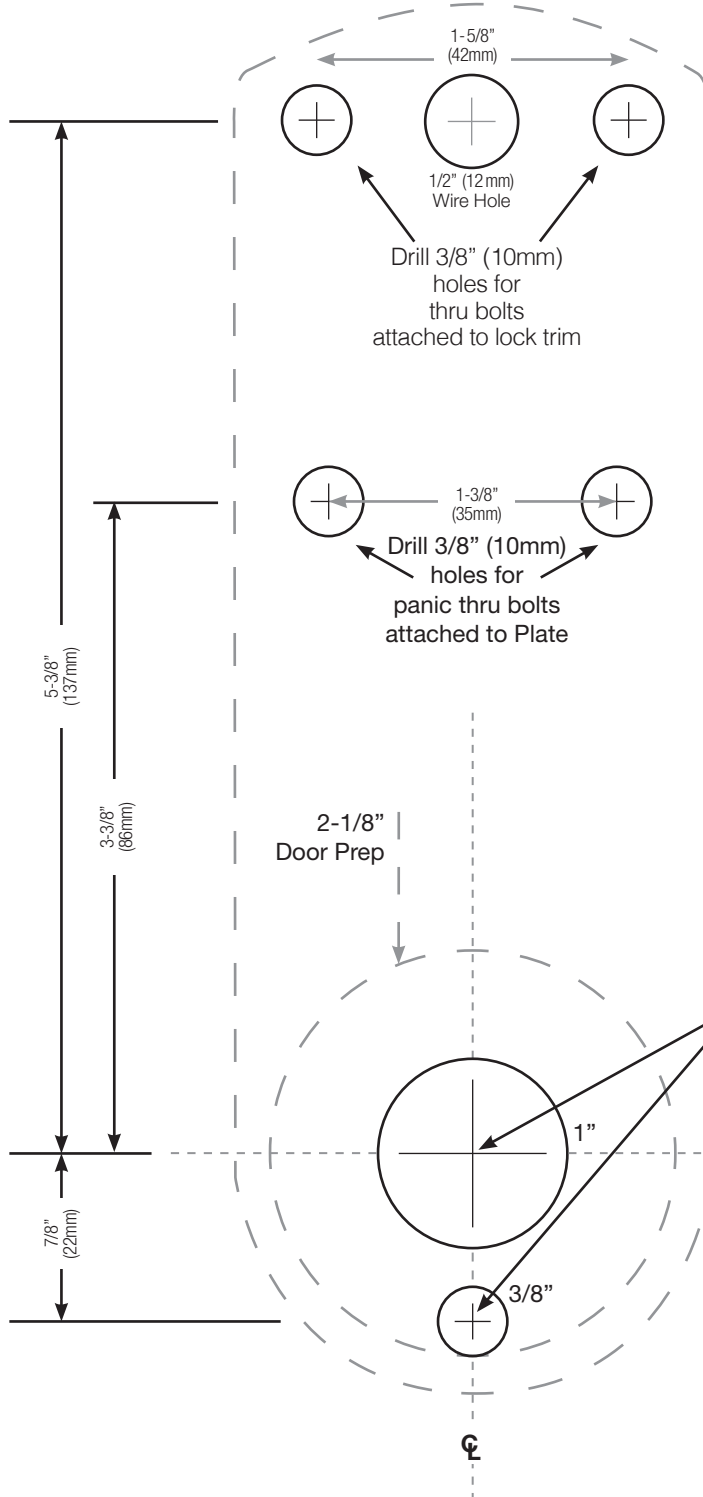

Drill 1/2"
(10mm)

Use metal flange to cover
2-1/8" door prep, to
attach bottom of lock trim.

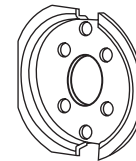

If there is no 2-1/8" Door Prep,
drill the following 1" dia. and
3/8" dia. holes.